

Agro Prime

agroprime.com.tr AGRICULTURAL MACHINERY



AP-PRO-5000 active

Lifting Capacity: Up to 12 tm

Maximum Reach: Up to 9 m

Overall Dimensions: l 0.95 m, width 2.46 m, h 2.25 m

Features: 380° rotation with rack and pinion



ROTATING: Self-centering cast iron ensures correct and stable connection between bearing and center rotation: pinion and rack, preventing wear and tear of teeth.

BASE: The base and bottom of the cast steel column provide excellent stress distribution and greater resistance.

BOOM GUIDE: Extension booms guide shoes minimize vertical and horizontal wear, less mounting clearance provides greater durability. With lubrication, friction force is reduced and easy movement is ensured and wear life is increased.

TANK: The metal tank is particularly impact resistant and provides protection against the corrosive action of any external element.

LUBRICATION SYSTEM: Base system maintenance and inspection operations to guarantee easier access for centralized lubrication.

STABILIZERS: Hydraulically extendable outriggers also support execution with hoses placed on the sides of outriggers.

CONTROL: Independent hydraulic distributor controls for control; Automatic hook system for positioning extension booms fold into the rear of the Crane cab when in transport position.



LIGHTING: Where strong and versatile light is needed: it helps you work safely, even in poor natural light conditions, the lighting leds can be activated.

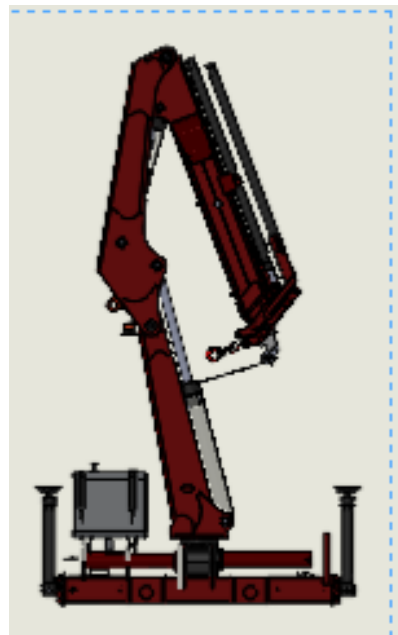
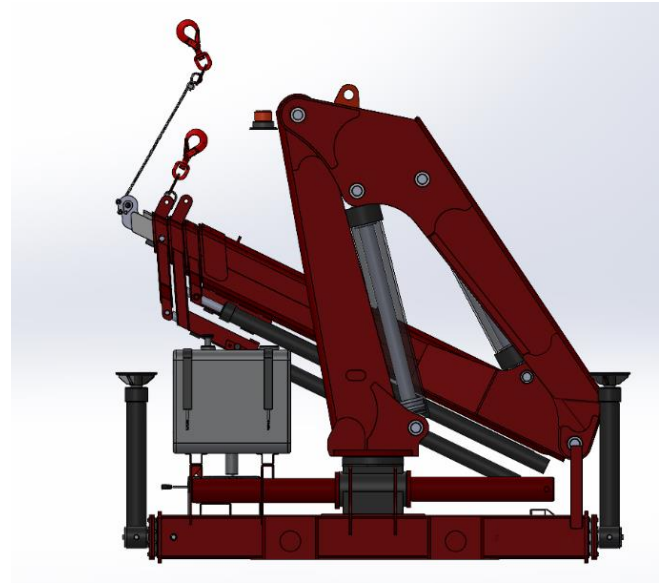
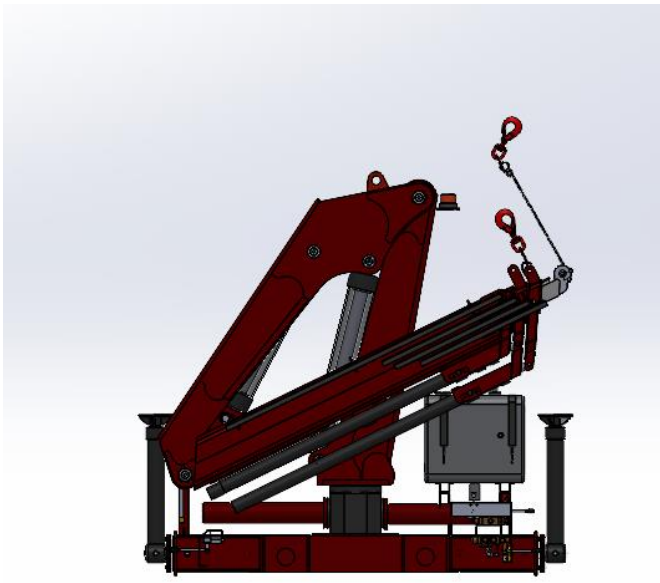

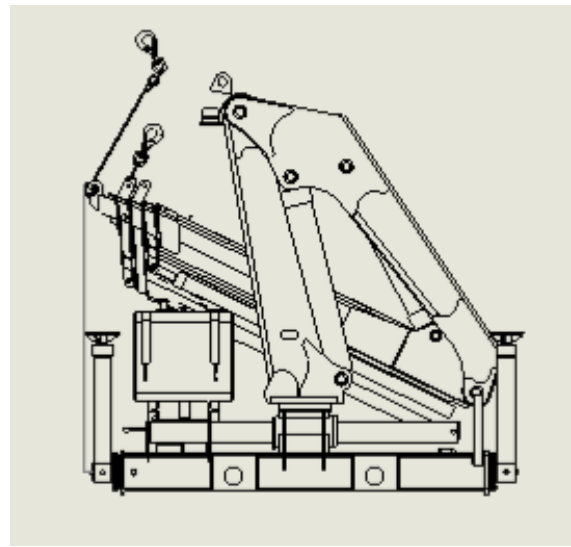
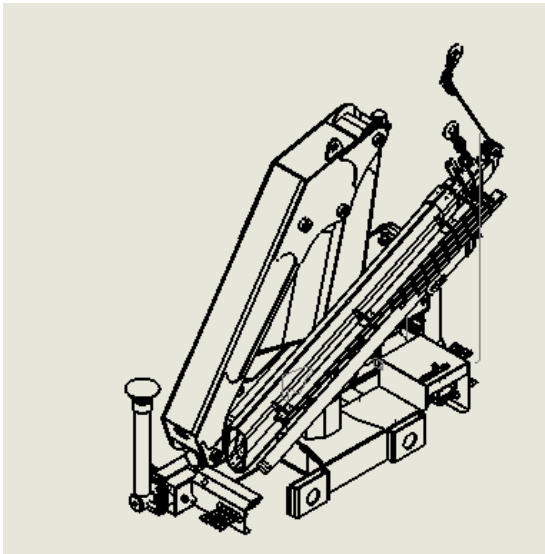
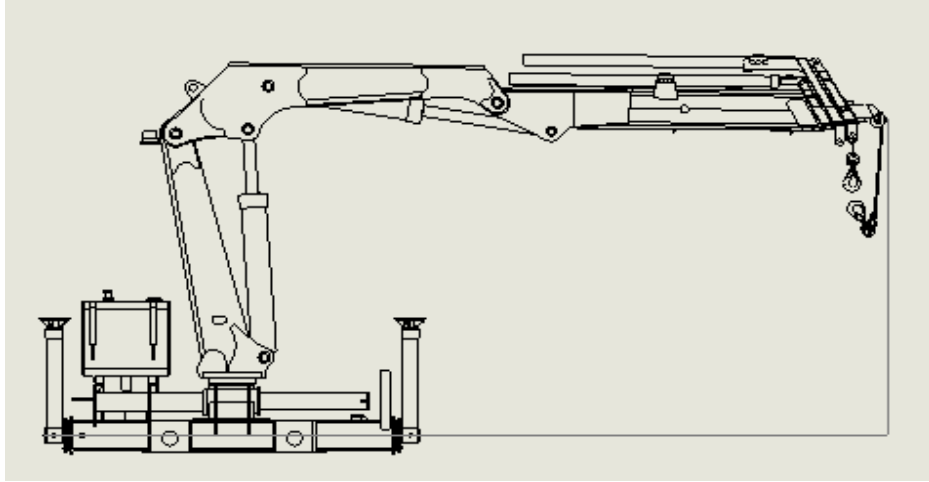
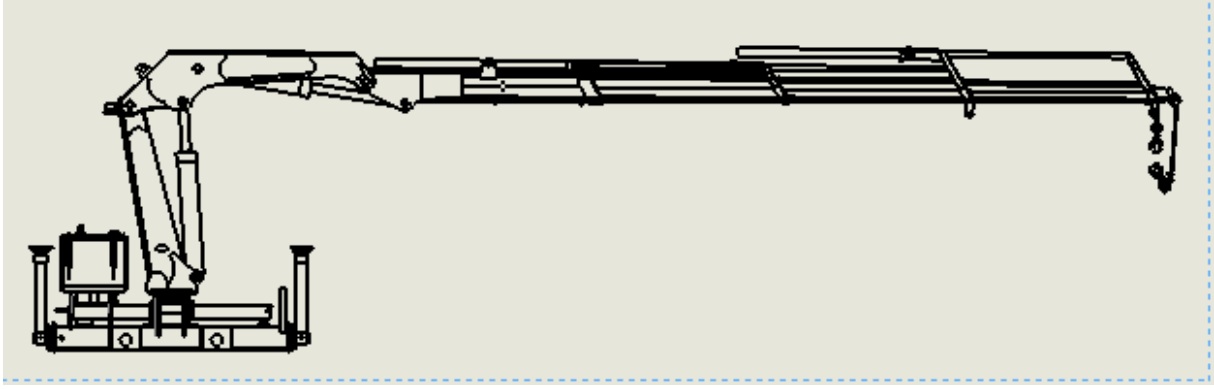

AgroPrime Machinery

[Mobil +905360736808](tel:+905360736808)

www.agroprime.com.tr

info@agroprime.com.tr